

UNCONTROLLED IF PRINTED; CONTROLLED COPY LOCATED IN IQMS DOCUMENT CONTROL

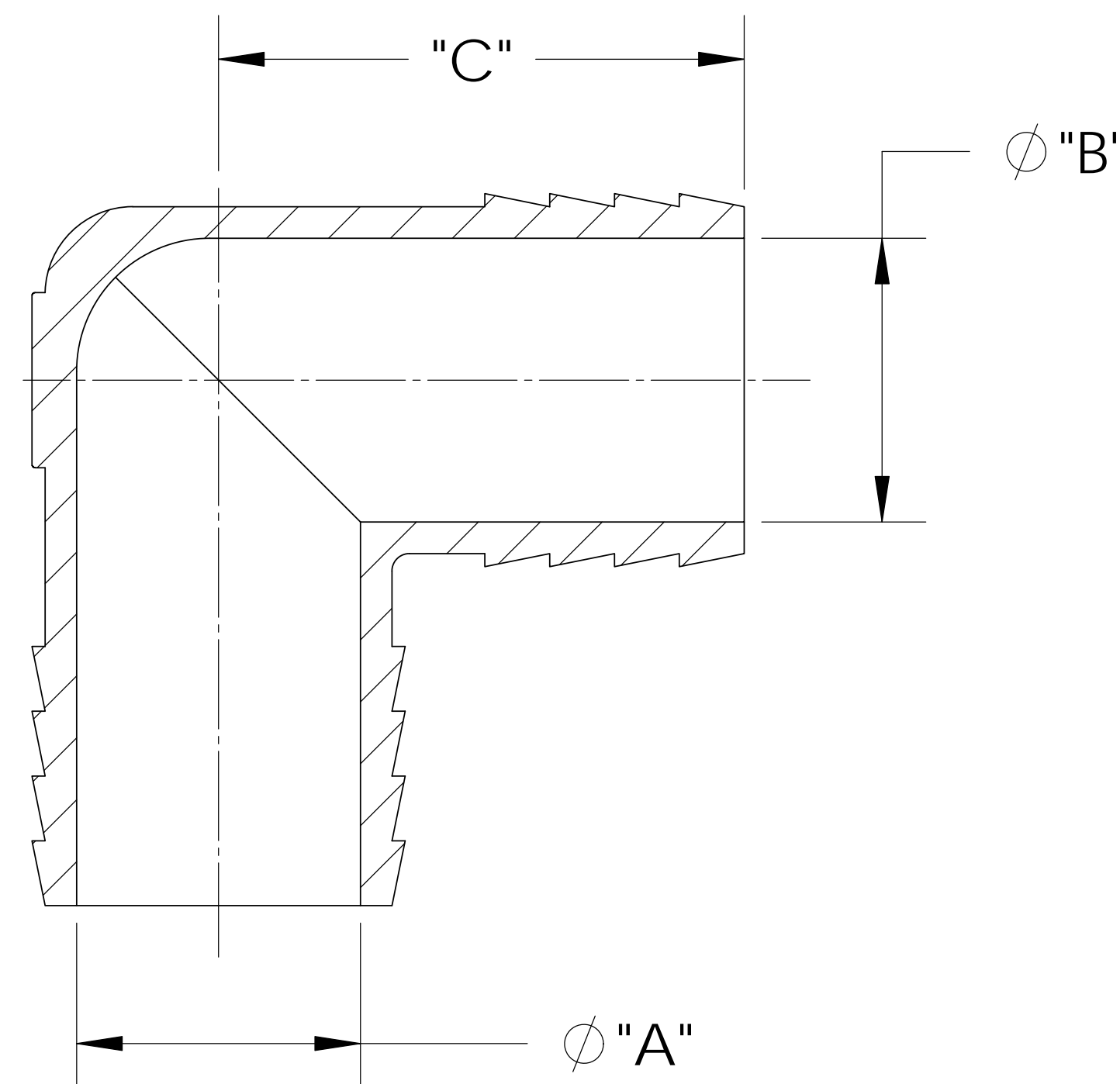

SECTION A-A

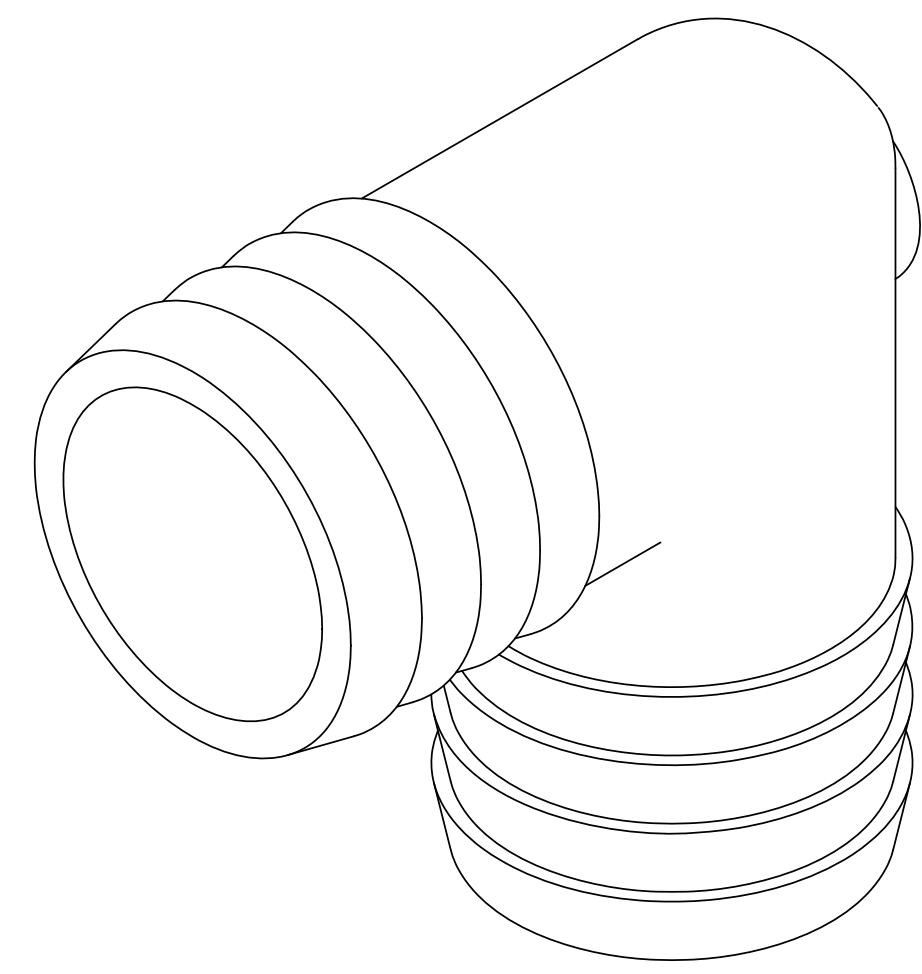
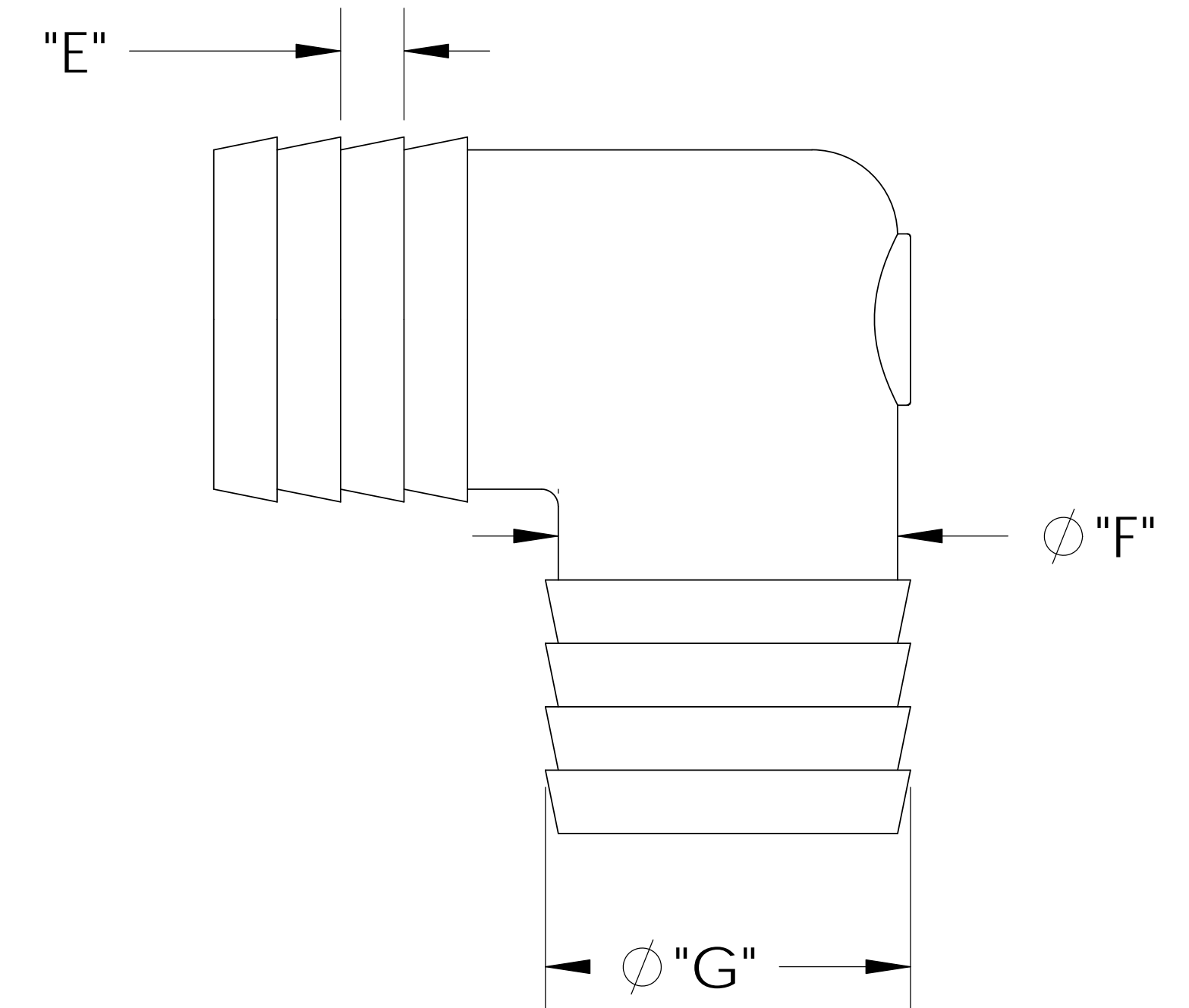
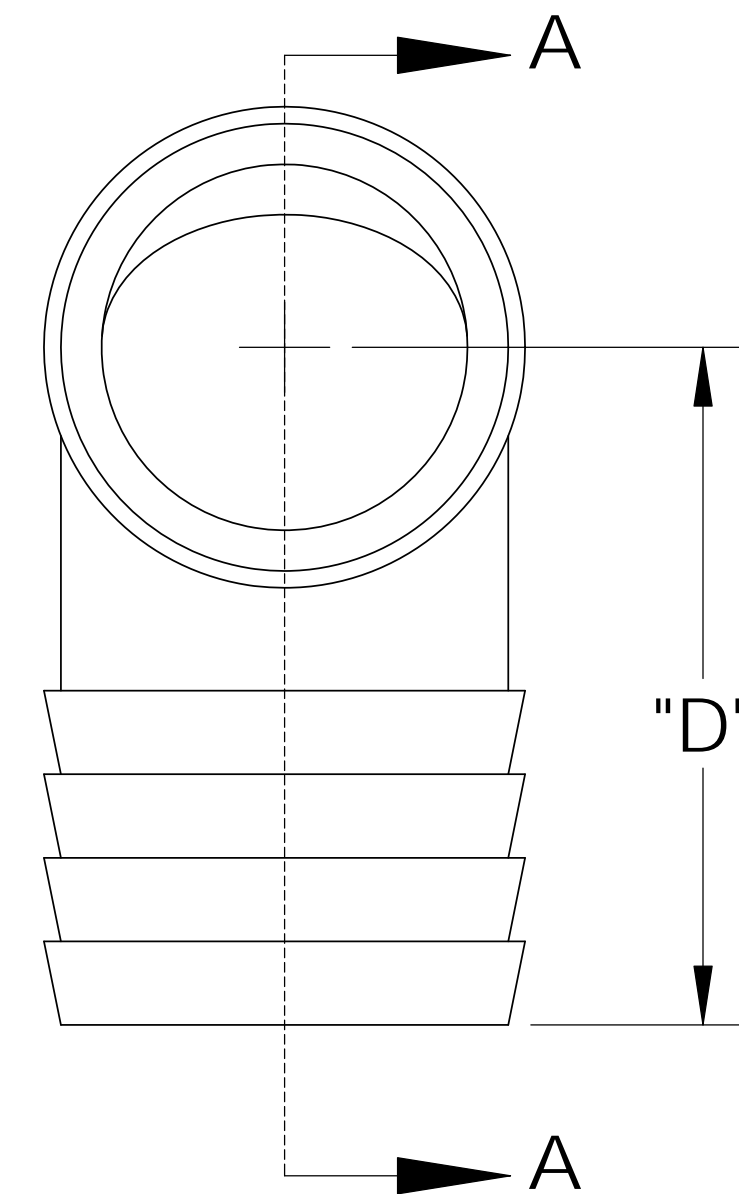

CATALOG NO.	DESCRIPTION	MATERIAL	DIM "A"	DIM "B"	DIM "C"	DIM "D"	DIM "E"	DIM "F"	DIM "G"
TE201616-T/PP	1" X 1" PP	POLYPROPYLENE	.795	.795	1.47	1.48	.185	.975	1.055
TE201616-T/P	1" X 1" P	POLYETHYLENE	.780	.780	1.44	1.46	.180	.965	1.03
TE201616-T/N	1" X 1" N	NYLON	.810	.810	1.50	1.50	.185	.990	1.065
TE201616-T/K	1" X 1" K	KYNAR	.810	.810	1.50	1.50	.185	.990	1.065

SHOWN

NOTES:

- 1) POLYPROPYLENE HAS COLOR OPTIONS:
 BLACK = TE201616-T/PPB
 NATURAL = TE201616-T/PPN

PROPRIETARY AND CONFIDENTIAL
 THE INFORMATION CONTAINED IN THIS DRAWING IS THE SOLE PROPERTY OF THOGUS PRODUCTS COMPANY. ANY REPRODUCTION IN PART OR AS A WHOLE WITHOUT THE WRITTEN PERMISSION OF THOGUS PRODUCTS COMPANY IS PROHIBITED.

REV	WRO#	DESCRIPTION
D	95.00035	CONVERTED TO 3D FORMAT
HISTORY		

UNLESS OTHERWISE SPECIFIED:
 DIMENSIONS ARE IN INCHES
 TOLERANCES:
 ANGULAR: ±0.5°
 X.X = ± 0.1
 X.XX = ± 0.05
 X.XXX = ± 0.015
 REMOVE ALL SHARP EDGES AND BURRS
 BLEND ALL RADII TO 0.01IN
 INTERPRET GEOMETRIC TOLERANCING PER: ANSI Y 14.5 1994
 MATERIAL: PP, P, N
 FINISH: NA
 THIRD ANGLE PROJECTION:

	NAME	DATE
DRAWN	KDJ	11/09/10
CHECKED	JM	11/9/10
ENG APPR.		XX/XX/XX
MFG APPR.		XX/XX/XX
Q.A.		XX/XX/XX

Thogus You think it, we can make it...
 33490 PIN OAK, AVON LAKE, OH 44012

TITLE: **BARB ELBOW, 1" X 1"**

SIZE B	DWG. NO. TE201616-T	REV D
SCALE: 1:1	MASS:	SHEET 1 OF 1

DO NOT SCALE DRAWING